

Description	Material	Finish
Body	Brass	Gold
Pin	Brass	Gold
Insulation	Teflon	Teflon
Snaps	BE CU	Gold
Crimp Ring	Brass	Gold
Insulator	Teflon	Gold
Cover	Brass	Nickel
Heat Shrink	Polyolefin	Black

REVISIONS			
REV	DESCRIPTION	DATE	APPV
B	New frame; revised heat shrink dimensions	1/13/10	CJ

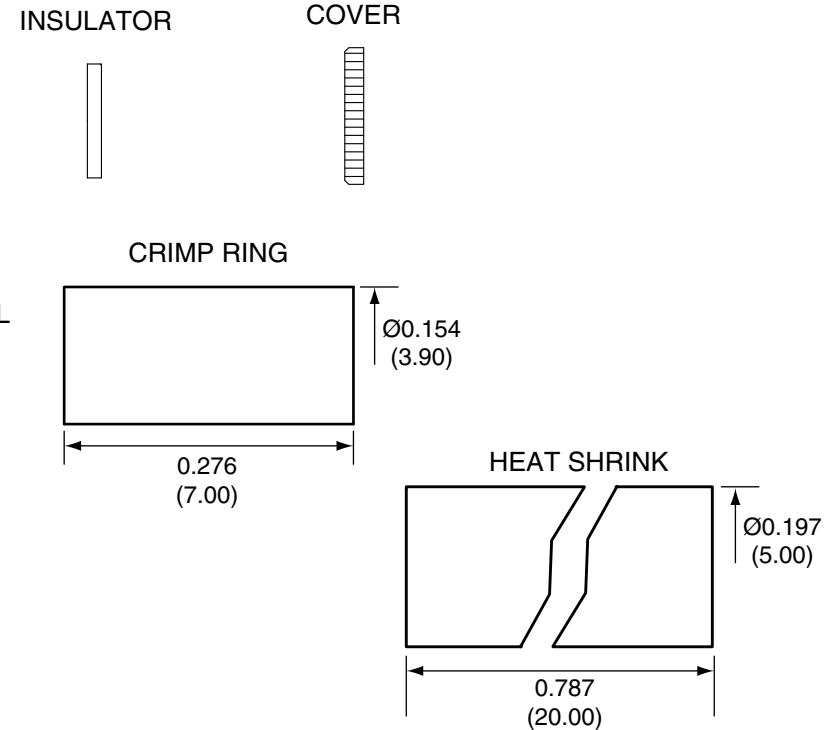
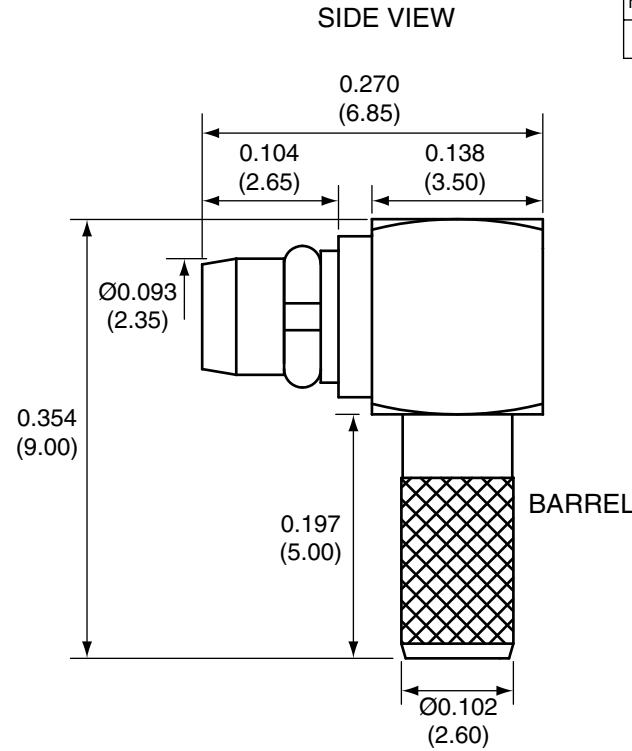

### Assembly Instructions

- Strip coax as shown. Put heat shrink, then crimp ring onto cable.
- Slide the coax into the body until the center conductor is centered in the fork.
- Push the shield over the barrel.
- Solder the center conductor into center of the fork.
- Slide the crimp ring over the shield and crimp with a 0.128" crimp die.
- Trim off any excess shield wire sticking out from the ring.
- Slip the heat shrink tube over the crimp ring until it is against the body and then heat shrink.
- Slip insulator into body.
- Push cover into the opening.

### NOTES: (UNLESS OTHERWISE SPECIFIED)

- ALL DIMENSIONS ARE IN INCHES [mm].
- DIMENSIONS APPLY AFTER FINISHING.
- MANUFACTURE TO BE COMPLIANT WITH EU RoHS DIRECTIVE.
- SAFETY BREAK ALL SHARP CORNERS AND EDGES .02 MAXIMUM.

### RECOMMENDED CABLE STRIPPING DIMENSIONS

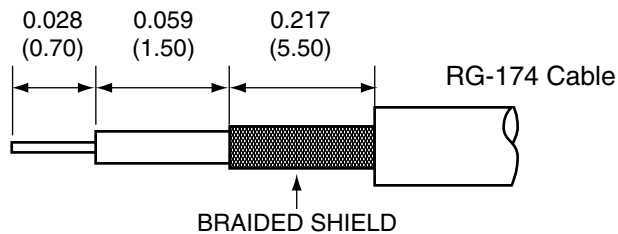

WARNING: THIS DRAWING CONTAINS PROPRIETARY INFORMATION THAT IS THE SOLE PROPERTY OF CONNECTOR CITY, AND SHALL BE TREATED AS SUCH. NO DISCLOSURE OR REPRODUCTION OF THIS DOCUMENT IS PERMITTED, IN WHOLE OR IN PART, WITHOUT THE EXPRESS WRITTEN PERMISSION OF CONNECTOR CITY OR ITS DESIGNATED AGENTS.

MATERIAL:	TOLERANCES:	PROJECTION: 
	.020 [0.50]-.200 [5.00]= ±.008 [0.20] .200 [5.00]-1.200 [30.00]= ±.016 [0.40] 1.20 [30.0]-4.75 [120.0]= ±.024 [0.60] 4.75 [120.0]-12.40 [315.0]= ±.040 [1.0]	
FINISH:	DRAWN: CJ	DT: 1/13/10
	ENGR:	DT:

**CONNECTOR CITY** 159 ORT LANE  
THE VALUE OF CONNECTIONS MERLIN, OR 97532

TITLE:  
**MMCX MALE RIGHT ANGLE  
CABLE END CRIMP FOR RG174 CABLE**

SIZE <b>A</b>	DWG. NO. <b>CONMMCX012</b>	REV <b>B</b>
SCALE: 2:1	DO NOT SCALE DRAWING	SHEET 1 OF 1