

1		
Description	Material	Finish
Body	Brass	Nickel
Pin	Brass	Gold
Insulation	Teflon	Teflon
Crimp Ring	Brass	Nickel

SIDE VIEW

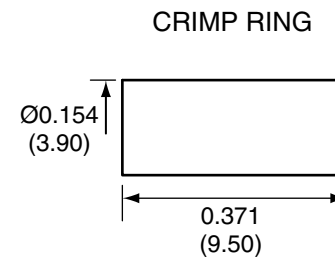

RECOMMENDED CABLE STRIPPING DIMENSIONS

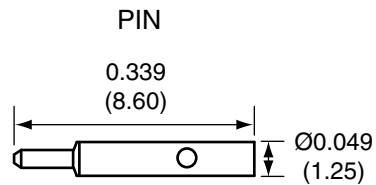
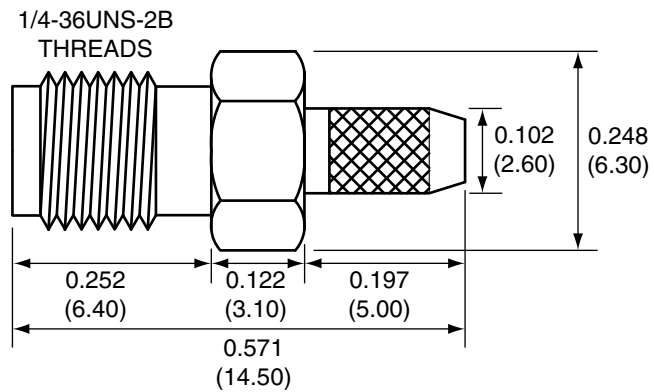
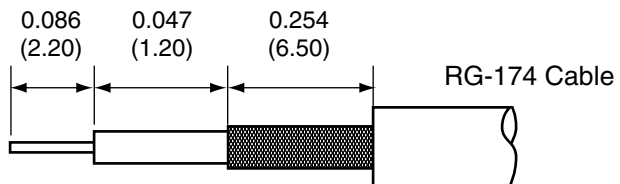

CONREVSMA011 ASSEMBLY INSTRUCTIONS

1. Solder the pin to the center conductor.
2. Insert the pin, center conductor, and insulator into the body.
3. Wrap the braid around the tail of the body and crimp the ring with a 0.137" hex crimp tool (or one labeled for use with RG-174 cable)

Title		RP-SMA FEMALE CABLE END CRIMP FOR RG174 CABLE		CONNECTOR CITY 159 ORT LANE MERLIN, OR 97532 PH (541)-471-6256 FAX (541)-471-6251	
Part No.	CONREVSMA011	Revision:	1.0		
Dimensions:	INCHES (mm)	Date:	3/2/2005	Sheet 1 of 1	

CONNECTOR CITY
THE VALUE OF CONNECTIONS